



Engine	Cummins QSL9.3
Rated Power	162 kW (217 hp / 220 ps) @ 2,200 rpm
Net Power	152 kW (204 hp / 207 ps) @ 2,200 rpm
Operating Weight	18,380 kg
Standard Bucket Size	3.5 m ³
Standard Breakout Force	181 kN
Standard Dump Clearance	2,955 mm

856H MAX WHEEL LOADER

856H MAX SPECIFICATIONS >>>

ENGINE

Emission Regulation	Tier 3 / Stage III
Manufacturer	Cummins
Model	QSL9.3
Rated Power	162 kW (217 hp / 220 ps) @ 2,200 rpm
Net Power	152 kW (204 hp / 207 ps) @ 2,200 rpm
Peak Torque	984 N·m @ 1,300 rpm
Displacement	9.3 L
Number of Cylinder	6
Aspiration	Turbocharged & air-to-air intercooled

TRANSMISSION

Transmission Type	Electro-hydraulic powershift
Torque Converter	Single stage, three elements
Maximum Travel Speed, fwd	36 km/h
Maximum Travel Speed, rev	24 km/h
Number of Speed, fwd	4
Number of Speed, Rev	3

AXLES

Differential Front Type	Limited slip
Differential Rear Type	Limited slip
Axle Oscillation	± 12°

STEERING

Steering Configuration	Piston
Steering Relief Pressure	20.7 MPa

BRAKES

Service Brake Type	Wet discs brake
Service Brake Actuation	Hydraulic
Parking Brake Type	Drum
Parking Brake Actuation	Electro-hydraulic release

HYDRAULIC SYSTEM

Main Pump Type	Piston
Main Relief Pressure	25 MPa
Raise	4.6 s
Dump Time	1.0 s
Float Down Time	3.0 s
Fastest Total Cycle Time	8.6 s

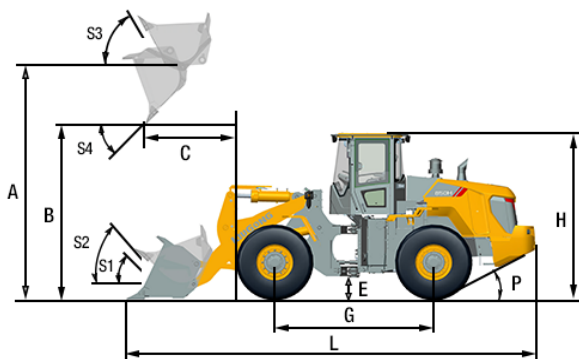

LOADER ARM PERFORMANCE with Standard Bucket 3.5 m³

Tipping Load - Straight (ISO 14397-1:2007)	13,880 kg
Tipping Load - Full Turn (ISO 14397-1:2007)	12,150 kg
Bucket Breakout Force	181 kN
A Maximum Hinge Pin Height	4,156 mm
B Dump Clearance at Full Height Discharge	2,955 mm
C Dump Reach at Full Height Discharge	1,207 mm
D Maximum Digging Depth, Bucket Level	50 mm
S ₁ Bucket Rollback at Ground Level	44°
S ₂ Bucket Rollback at Carry	49°
S ₃ Bucket Rollback at Maximum Height	57°
S ₄ Maximum Dump Angle at Full Height	45°

BUCKET PERFORMANCE

Reference Bucket	2.7 - 5.6 m ³
------------------	--------------------------

DIMENSIONS

E Ground Clearance	431 mm
G Wheelbase	3,320 mm
H Cab Height	3,500 mm
J Wheel Tread	2,150 mm
K Width Over Tires	2,750 mm
L Length with Bucket Down	8,437 mm
M Turn Angle, Either Side	38°
P Rear Angle of Departure	27°
R ₁ Turning Radius, Bucket Carry	6,913 mm
R ₂ Turning Radius, Outside of Tire	6,205 mm
W Width Over Bucket	2,970 mm

TIRES

Tire Size	23.5-25 PR20 L-3 TT
-----------	---------------------

OPERATING WEIGHTS

Operating Weight	18,380 kg
------------------	-----------

SERVICE CAPACITY

Fuel Tank	270 L
Engine Oil	26 L
Cooling System	50 L
Hydraulic System	240 L
Transmission and Torque Converter	35 L
Axles, Front/Rear	40 L/42 L

